

Approval body for construction products
and types of construction

Bautechnisches Prüfamt

An institution established by the Federal and
Laender Governments



European Technical Assessment

ETA-16/0308
of 11 December 2019

English translation prepared by DIBt - Original version in German language

General Part

Technical Assessment Body issuing the
European Technical Assessment:

Deutsches Institut für Bautechnik

Trade name of the construction product

TURBO SMART

Product family
to which the construction product belongs

Mechanical fasteners for use in concrete

Manufacturer

pgb - Polska Sp. z o.o.
ul. Fryderyka Wilhelma Redena 3
41-807 ZABRZE
POLEN

Manufacturing plant

manufacturing plant 3

This European Technical Assessment
contains

22 pages including 3 annexes which form an integral part
of this assessment

This European Technical Assessment is
issued in accordance with Regulation (EU)
No 305/2011, on the basis of

EAD 330232-00-0601

This version replaces

ETA-16/0308 issued on 23 May 2016

The European Technical Assessment is issued by the Technical Assessment Body in its official language. Translations of this European Technical Assessment in other languages shall fully correspond to the original issued document and shall be identified as such.

Communication of this European Technical Assessment, including transmission by electronic means, shall be in full. However, partial reproduction may only be made with the written consent of the issuing Technical Assessment Body. Any partial reproduction shall be identified as such.

This European Technical Assessment may be withdrawn by the issuing Technical Assessment Body, in particular pursuant to information by the Commission in accordance with Article 25(3) of Regulation (EU) No 305/2011.

Specific Part

1 Technical description of the product

The TURBO SMART concrete screw is an anchor of size 6, 8, 10, 12 and 14 mm made of galvanised steel respectively steel with zinc flake coating, made of stainless or high corrosion resistant steel. The anchor is screwed into a predrilled cylindrical drill hole. The special thread of the anchor cuts an internal thread into the member while setting. The anchorage is characterised by mechanical interlock in the special thread.

Product and product description is given in Annex A.

2 Specification of the intended use in accordance with the applicable European Assessment Document

The performances given in Section 3 are only valid if the anchor is used in compliance with the specifications and conditions given in Annex B.

The verifications and assessment methods on which this European Technical Assessment is based lead to the assumption of a working life of the anchor of at least 50 years. The indications given on the working life cannot be interpreted as a guarantee given by the producer, but are to be regarded only as a means for choosing the right products in relation to the expected economically reasonable working life of the works.

3 Performance of the product and references to the methods used for its assessment

3.1 Mechanical resistance and stability (BWR 1)

| Essential characteristic | Performance |
|--|---------------------------------|
| Characteristic resistance to tension load (static and quasi-static loading) | See Annex C 1 and C 2 |
| Characteristic resistance to shear load (static and quasi-static loading) | See Annex C 1 and C 2 |
| Displacements (static and quasi-static loading) | See Annex C 7 |
| Characteristic resistance and displacements for seismic performance categories C1 and C2 | See Annex C 3, C 4, C 5 and C 8 |

3.2 Safety in case of fire (BWR 2)

| Essential characteristic | Performance |
|--------------------------|---------------|
| Reaction to fire | Class A1 |
| Resistance to fire | See Annex C 6 |

4 Assessment and verification of constancy of performance (AVCP) system applied, with reference to its legal base

In accordance with European Assessment Document EAD No. 330232-00-0601 the applicable European legal act is: [96/582/EC].

The system to be applied is: 1

5 Technical details necessary for the implementation of the AVCP system, as provided for in the applicable European Assessment Document

Technical details necessary for the implementation of the AVCP system are laid down in the control plan deposited at Deutsches Institut für Bautechnik.

Issued in Berlin on 11 December 2019 by Deutsches Institut für Bautechnik

Dr.-Ing. Lars Eckfeldt
p. p. Head of Department

beglaubigt:
Tempel

Product and installed condition

TURBO SMART concrete screw

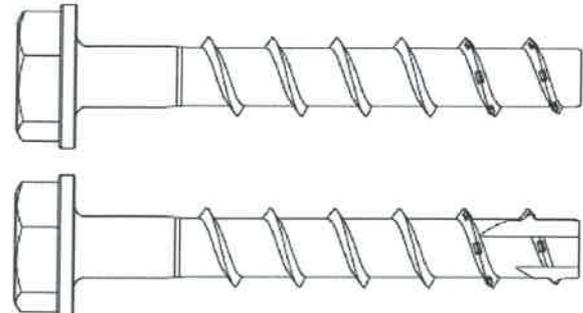
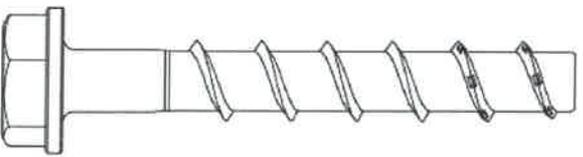
| | |
|--|---|
|  | <p>Carbon steel, zinc-plated and zinc-flake coating</p> |
|  | <p>Stainless steel A4 and HCR</p> |

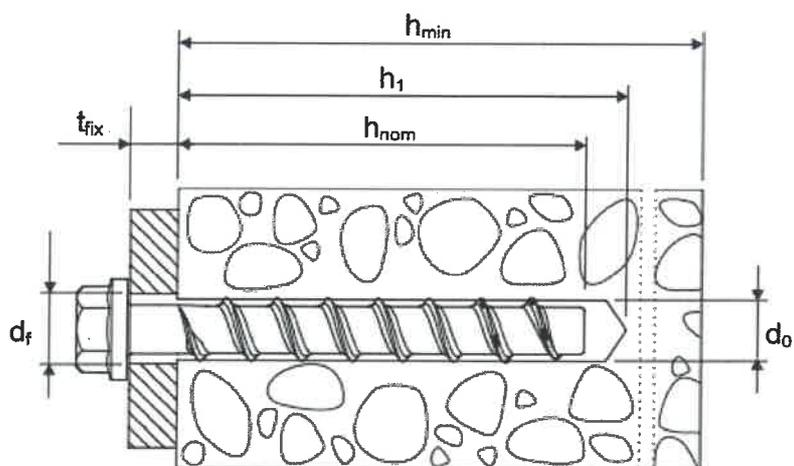

- d_0 = nominal drill bit diameter
- h_{nom} = nominal anchorage depth
- h_1 = depth of the drill hole
- h_{min} = minimum thickness of member
- t_{fix} = thickness of fixture
- d_f = diameter of clearance hole in the fixture

TURBO SMART concrete screw

Product description
Installed condition

Annex A1

| | | | | |
|----|--|---|----------------------|--|
| 1 |  |  | TURBO SMART S-BSZ | Concrete screw version with hexagon head with pressed-on washer |
| 2 |  |  | TURBO SMART S-BSM | Concrete screw version with hexagon head with pressed-on washer and T-drive |
| 3 | |  | TURBO SMART S-BSH | Concrete screw version with hexagon head |
| 4 | |  | TURBO SMART S-BSV | Concrete screw with countersunk head |
| 5 | |  | TURBO SMART S-BSP | Concrete screw with pan head |
| 6 | |  | TURBO SMART S-BSF | Concrete screw with large pan head |
| 7 | |  | TURBO SMART S-BSE | Concrete screw with countersunk head and connection thread |
| 8 | |  | TURBO SMART S-BSB | Concrete screw with hexagonal head and connection thread |
| 9 | |  | TURBO SMART S-BSS | Concrete screw with hexagon drive and connection thread |
| 10 | |  | TURBO SMART S-BSA | Concrete screw with connection thread and hexagon socket drive |
| 11 | |  | TURBO SMART S-BSI | Concrete screw with internal metric thread and hexagon drive |

TURBO SMART concrete screw

Product description
Versions

Annex A2

Table A1: Materials

| Part | Name | Type | Material | f_{yk} | f_{uk} |
|------|----------------|-----------------|---|-----------------------|-----------------------|
| 1 | Concrete screw | TURBO SMART | Steel EN 10263-4:2017, zinc-plated acc. to EN ISO 4042:2018 or zinc flake coating acc. to EN ISO 10683:2018 ($\geq 5\mu\text{m}$) | 560 N/mm ² | 700 N/mm ² |
| 2 | | | | | |
| 3 | | | | | |
| 4 | | | | | |
| 5 | | TURBO SMART A4 | 1.4401, 1.4404, 1.4571, 1.4578 | | |
| 6 | | | | | |
| 7 | | | | | |
| 8 | | TURBO SMART HCR | 1.4529 | | |
| 9 | | | | | |
| 10 | | | | | |
| 11 | | | | | |

f_{yk} = nominal characteristic steel yield strength
 f_{uk} = nominal characteristic steel ultimate strength

Table A2: Dimensions

| Anchor size | | 6 | | 8 | | | 10 | | | 12 | | | 14 | | | |
|-------------------------|----------|-----------|-----|----|------|----|----|------|----|----|------|----|-----|------|-----|-----|
| Nominal embedment depth | | h_{nom} | 1 | | 2 | | 3 | | 1 | | 2 | | 3 | | | |
| | | [mm] | 40 | 55 | 45 | 55 | 65 | 55 | 75 | 85 | 65 | 85 | 100 | 75 | 100 | 115 |
| Screw length | $\leq L$ | [mm] | 500 | | | | | | | | | | | | | |
| Core diameter | d_k | [mm] | 5,1 | | 7,1 | | | 9,1 | | | 11,1 | | | 13,1 | | |
| Thread outer diameter | d_s | [mm] | 7,5 | | 10,6 | | | 12,6 | | | 14,6 | | | 16,6 | | |
| Shaft diameter | d_p | [mm] | 5,7 | | 7,9 | | | 9,9 | | | 11,7 | | | 13,7 | | |



Marking:

TURBO SMART (Zinc plated and Zinc flake)

Anchor type: TSM

Anchor size: 10

Length of the anchor: 100



TURBO SMART A4

Anchor type: TSM

Anchor size: 10

Length of the anchor: 100

Material: A4



TURBO SMART HCR

Anchor type: TSM

Anchor size: 10

Length of the anchor: 100

Material: HCR

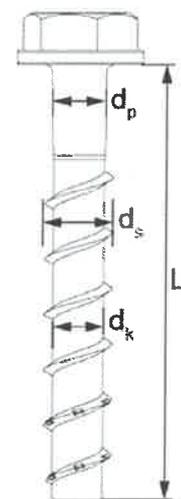

TURBO SMART concrete screw

Product description

Materials, dimensions and markings

Annex A3

Intended use

Table B1: Anchorages subject to

| TURBO SMART concrete screw | | 6 | | 8 | | | 10 | | | 12 | | | 14 | | |
|--|-----------|------------------------------------|------------|------------|------------|------------|------------|------------|------------|------------|------------|------------|------------|------------|------------|
| Nominal embedment depth | h_{nom} | h_{nom1} | h_{nom2} | h_{nom1} | h_{nom2} | h_{nom3} | h_{nom1} | h_{nom2} | h_{nom3} | h_{nom1} | h_{nom2} | h_{nom3} | h_{nom1} | h_{nom2} | h_{nom3} |
| | [mm] | 40 | 55 | 45 | 55 | 65 | 55 | 75 | 85 | 65 | 85 | 100 | 65 | 85 | 115 |
| Static and quasi-static loads | | All sizes and all embedment depths | | | | | | | | | | | | | |
| Fire exposure | | | | | | | | | | | | | | | |
| C1 category - seismic performance | | | | | | | | | | | | | | | |
| C2 category – seismic (A4 and HCR not suitable) | | x | | x | | ok | | x | | ok | | x | | ok | |

Base materials:

- Reinforced and unreinforced concrete without fibers according to EN 206:2013.
- Strength classes C20/25 to C50/60 according to EN 206:2013.
- Cracked and uncracked concrete.

Use conditions (Environmental conditions):

- Concrete screws subject to dry internal conditions: all screw types.
- Structural subject to external atmospheric exposure (including industrial and marine environment) and to permanently damp internal condition no particular aggressive conditions exist screw types made of stainless steel with marking A4.
- Structural subject to external atmospheric exposure (including industrial and marine environment) and to permanently damp internal condition if particular aggressive conditions exist: screw types made of stainless steel with marking HCR.
Note: Such particular aggressive conditions are e.g. permanent, alternating immersion in seawater or splash zone of seawater, chloride atmosphere of indoor swimming pools or atmosphere with chemical pollution (e.g. in desulphurization plants or road tunnels where de-icing materials are used).

TURBO SMART concrete screw

Intended use
Specification

Annex B1

Intended use

Design:

- Anchorages are to be designed under the responsibility of an engineer experienced in anchorages and concrete work.
- Verifiable calculation notes and drawings are to be prepared taking account of the loads to be anchored. The position of the anchor is indicated on the design drawings (e.g. position of the anchor relative to reinforcement or to supports, etc.).
- Anchorages are designed according to EN 1992-4:2018 and EOTA Technical Report TR 055. The design for shear load according to EN 1992-4:2018, Section 6.2.2 applies for all specified diameters d_f of clearance hole in the fixture in Annex B3, Table B2.

Installation:

- Hammer drilling or hollow drilling; hollow drilling only for sizes 8-14.
- Anchor installation carried out by appropriately qualified personal and under the supervision of the person responsible for technical matters on site.
- In case of aborted hole: new drilling must be drilled at a minimum distance of twice the depth of aborted hole or closer, if the aborted hole is filled with high strength mortar and only if the hole is not in the direction of the oblique tensile or shear load.
- After installation further turning of the anchor must not be possible. The head of the anchor is supported in the fixture and is not damaged.
- The borehole may be filled with injection mortar SMART S-IRV, S-IRW or S-IRE.
- Adjustability according to Annex B6 for sizes 8-14, all embedment depths, but not for seismic loading
- Cleaning of borehole is not necessary, if using a hollow drill bit.

TURBO SMART concrete screw

Intended use
Specification

Annex B2

Table B2: Installation parameters

| TURBO SMART concrete screw size | | | 6 | | 8 | | | 10 | | | |
|--|----------------|-----------|--|------------|------------|------------|------------|------------|------------|------------|--|
| Nominal embedment depth | | h_{nom} | h_{nom1} | h_{nom2} | h_{nom1} | h_{nom2} | h_{nom3} | h_{nom1} | h_{nom2} | h_{nom3} | |
| | | [mm] | 40 | 55 | 45 | 55 | 65 | 55 | 75 | 85 | |
| Nominal drill hole diameter | d_0 | [mm] | 6 | | 8 | | | 10 | | | |
| Cutting diameter of drill bit | $d_{cut} \leq$ | [mm] | 6,40 | | 8,45 | | | 10,45 | | | |
| Drill hole depth | $h_1 \geq$ | [mm] | 45 | 60 | 55 | 65 | 75 | 65 | 85 | 95 | |
| Clearance hole diameter | $d_f \leq$ | [mm] | 8 | | 12 | | | 14 | | | |
| Installation torque (version with connection thread) | T_{inst} | [Nm] | 10 | | 20 | | | 40 | | | |
| Torque impact screw driver | | [Nm] | Max. torque according to manufacturer's instructions | | | | | | | | |
| | | | 160 | | 300 | | | 400 | | | |

| TURBO SMART concrete screw size | | | 12 | | | 14 | | |
|--|----------------|-----------|--|------------|------------|------------|------------|------------|
| Nominal embedment depth | | h_{nom} | h_{nom1} | h_{nom2} | h_{nom3} | h_{nom1} | h_{nom2} | h_{nom3} |
| | | [mm] | 65 | 85 | 100 | 75 | 100 | 115 |
| Nominal drill hole diameter | d_0 | [mm] | 12 | | | 14 | | |
| Cutting diameter of drill bit | $d_{cut} \leq$ | [mm] | 12,50 | | | 14,50 | | |
| Drill hole depth | $h_1 \geq$ | [mm] | 75 | 95 | 110 | 85 | 110 | 125 |
| Clearance hole diameter | $d_f \leq$ | [mm] | 16 | | | 18 | | |
| Installation torque (version with connection thread) | T_{inst} | [Nm] | 60 | | | 80 | | |
| Torque impact screw driver | | [Nm] | Max. torque according to manufacturer's instructions | | | | | |
| | | | 650 | | | 650 | | |

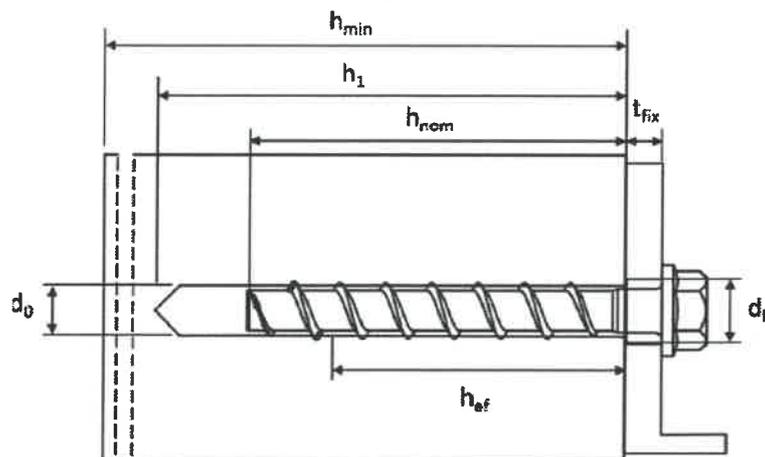

TURBO SMART concrete screw

Intended use
Installation parameters

Annex B3

Table B3: Minimum thickness of member, minimum edge distance and minimum spacing

| TURBO SMART concrete screw size | | | 6 | | 8 | | | 10 | | |
|---------------------------------|-----------|-----------|------------|------------|------------|------------|------------|------------|------------|------------|
| Nominal embedment depth | | h_{nom} | h_{nom1} | h_{nom2} | h_{nom1} | h_{nom2} | h_{nom3} | h_{nom1} | h_{nom2} | h_{nom3} |
| | | [mm] | 40 | 55 | 45 | 55 | 65 | 55 | 75 | 85 |
| Minimum thickness of member | h_{min} | [mm] | 100 | | 100 | | 120 | 100 | 130 | |
| Minimum edge distance | c_{min} | [mm] | 40 | 40 | 50 | | 50 | | | |
| Minimum spacing | s_{min} | [mm] | 40 | 40 | 50 | | 50 | | | |

| TURBO SMART concrete screw size | | | 12 | | | 14 | | |
|---------------------------------|-----------|-----------|------------|------------|------------|------------|------------|------------|
| Nominal embedment depth | | h_{nom} | h_{nom1} | h_{nom2} | h_{nom3} | h_{nom1} | h_{nom2} | h_{nom3} |
| | | [mm] | 65 | 85 | 100 | 75 | 100 | 115 |
| Minimum thickness of member | h_{min} | [mm] | 120 | 130 | 150 | 130 | 150 | 170 |
| Minimum edge distance | c_{min} | [mm] | 50 | | 70 | 50 | 70 | |
| Minimum spacing | s_{min} | [mm] | 50 | | 70 | 50 | 70 | |

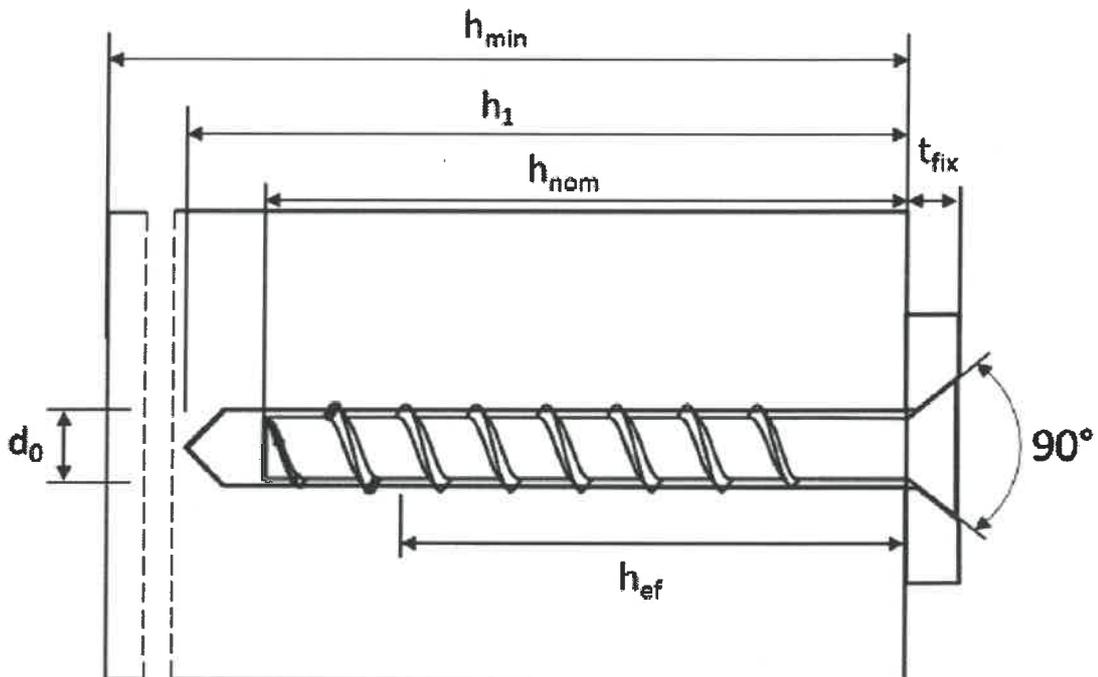

TURBO SMART concrete screw

Intended use
Installation instructions

Annex B4

Installation instructions

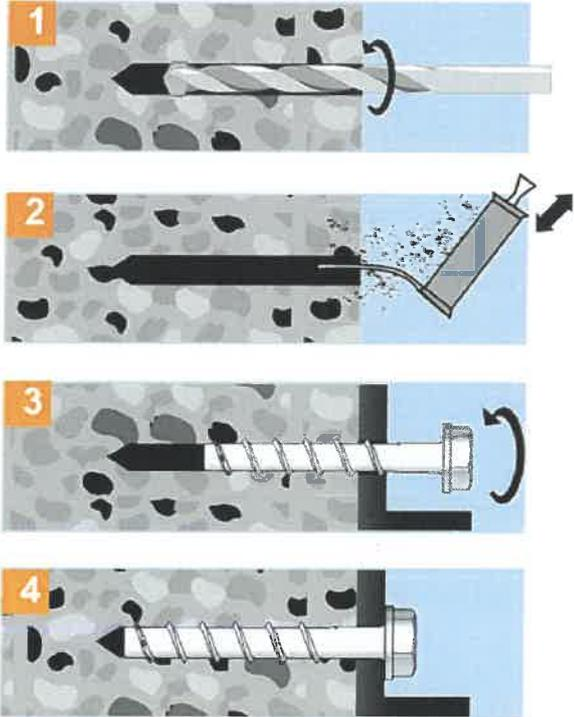
| | |
|--|---|
|  | <ol style="list-style-type: none">1. Drilling: Create hammer drilled or hollow drilled borehole.2. Cleaning of the drill hole: Remove drill dust by vacuuming or blowing.3. Installation: Install the anchor by impact screwdriver or torque wrench.4. Complete: verify that the head is pressed to the fixture. |
|--|---|

Remark: cleaning of borehole is not necessary when using an hollow drill bit

TURBO SMART concrete screw

Intended use
Installation instructions

Annex B5

Installation instructions for adjustability

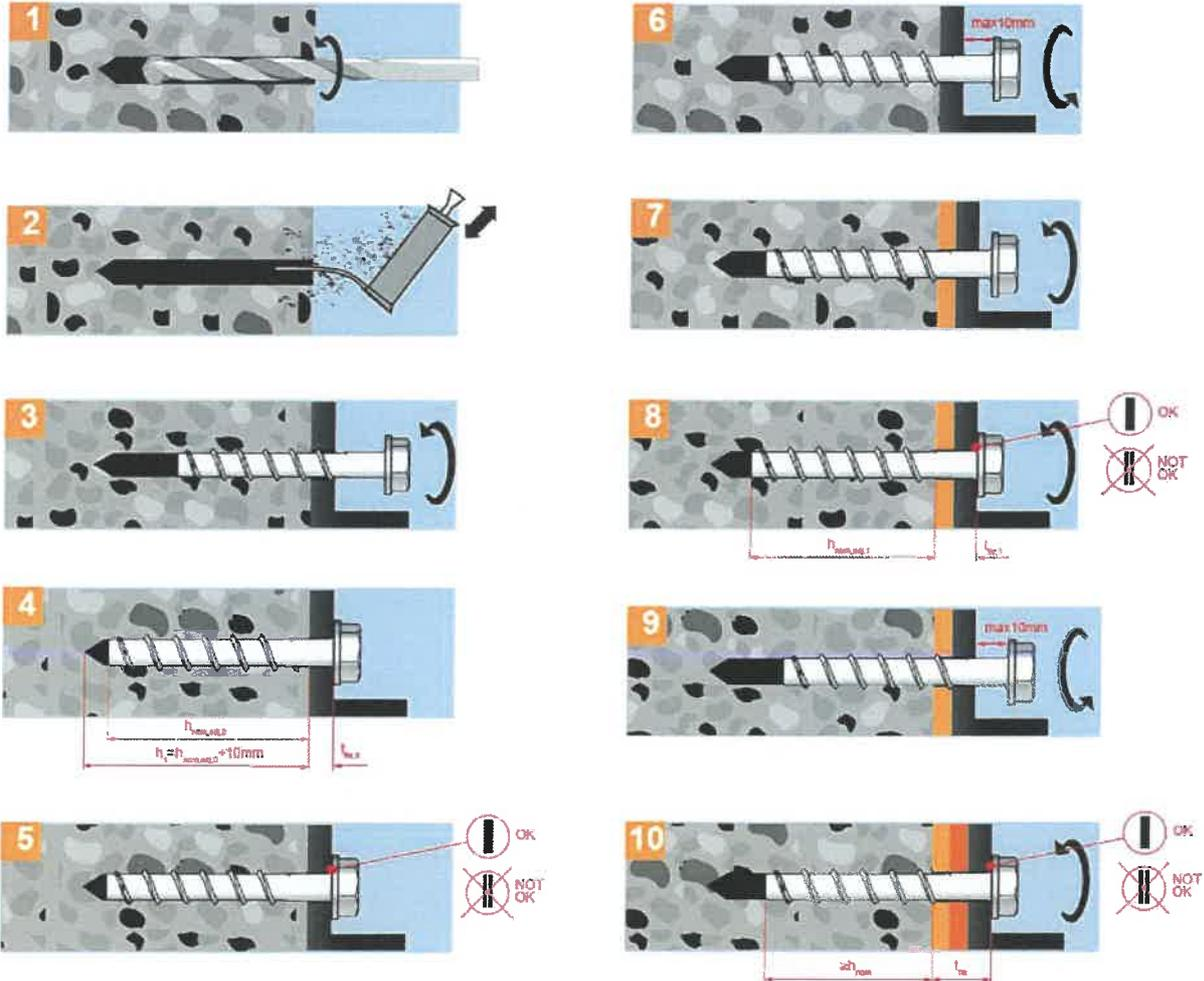

Installation instructions

TURBO SMART anchor may be adjusted maximum two times while the anchor may turn back at most 10 mm. The total allowed thickness of shims added during the adjustment process is 10mm. The final embedment depth after adjustment process must be equal or larger than h_{nom} .

TURBO SMART concrete screw

Intended use

Installation instructions for adjustability

Annex B6

Installation instructions – filling annular gap

| | |
|--|---|
| | <ol style="list-style-type: none"> 1. Drilling: Create hammer drilled or hollow drilled borehole. 2. Cleaning of the drill hole: Remove drill dust by vacuuming or blowing. 3. Filling washer: After preparing the borehole (Annex B5, figure 1+2), position first the fixture and then the filling washer. 4. Installation: Install the anchor by impact screwdriver or torque wrench. 5. Installed condition without injected mortar in the filling washer 6. Follow the instructions displayed on the chemical anchor cartridge and discard the mortar until the colour is constant. 7. Filling the annular gap: Fill the annular gap with the injection mortar (minimum compression strength of 20 N/mm², e.g. SMART S-IRV, S-IRW or S-IRE) |
|--|---|

Notes:

- For seismic loading the installation with filled and without filled annular gap is approved. Difference in performance can be found in Annex C3 – C5.
- No consideration of curing time is necessary.

TURBO SMART concrete screw

Intended use

Installation instructions - Filling annular gap

Annex B7

Table C1: Characteristic values for static and quasi-static loading, sizes 6, 8 and 10

| TURBO SMART concrete screw size | | | 6 | | | 8 | | | 10 | | |
|--|-----------------|-----------------|------------|---------------------|------------|------------|------------|------------|------------|-------------------|------------|
| Nominal embedment depth | h_{nom} | [mm] | h_{nom1} | h_{nom2} | h_{nom3} | h_{nom1} | h_{nom2} | h_{nom3} | h_{nom1} | h_{nom2} | h_{nom3} |
| | | | | 40 | 55 | 45 | 55 | 65 | 55 | 75 | 85 |
| Steel failure for tension and shear loading | | | | | | | | | | | |
| Characteristic tension load | $N_{Rk,s}$ | [kN] | 14,0 | | | 27,0 | | | 45,0 | | |
| Partial factor tension load | $\gamma_{Ms,N}$ | [-] | 1,5 | | | | | | | | |
| Characteristic shear load | $V_{Rk,s}$ | [kN] | 7,0 | 13,5 | 17,0 | 22,5 | 34,0 | | | | |
| Partial factor shear load | $\gamma_{Ms,V}$ | [-] | 1,25 | | | | | | | | |
| Ductility factor | k_7 | [-] | 0,8 | | | | | | | | |
| Characteristic bending load | $M^0_{Rk,s}$ | [Nm] | 10,9 | | | 26,0 | | | 56,0 | | |
| Pull-out failure | | | | | | | | | | | |
| Characteristic tension load C20/25 | cracked | $N_{Rk,p}$ | [kN] | 2,0 | 4,0 | 5,0 | 9,0 | 12,0 | 9,0 | $\geq N^0_{Rk,c}$ | |
| | uncracked | $N_{Rk,p}$ | [kN] | 4,0 | 9,0 | 7,5 | 12,0 | 16,0 | 12,0 | 20,0 | 26,0 |
| Increasing factor for $N_{Rk,p}$ | C20/25 | ψ_c | [-] | 1,12 | | | | | | | |
| | C30/37 | | | 1,22 | | | | | | | |
| | C40/50 | | | 1,41 | | | | | | | |
| | C50/60 | | | 1,58 | | | | | | | |
| Concrete failure: Splitting failure, concrete cone failure and pry-out failure | | | | | | | | | | | |
| Effective embedment depth | h_{ef} | [mm] | 31 | 44 | 35 | 43 | 52 | 43 | 60 | 68 | |
| k-factor | cracked | $k_1 = k_{cr}$ | [-] | 7,7 | | | | | | | |
| | uncracked | $k_1 = k_{ucr}$ | [-] | 11,0 | | | | | | | |
| Concrete cone failure | spacing | $s_{cr,N}$ | [mm] | $3 \times h_{ef}$ | | | | | | | |
| | edge distance | $c_{cr,N}$ | [mm] | $1,5 \times h_{ef}$ | | | | | | | |
| Splitting failure | spacing | $s_{cr,Sp}$ | [mm] | 120 | 160 | 120 | 140 | 150 | 140 | 180 | 210 |
| | edge distance | $c_{cr,Sp}$ | [mm] | 60 | 80 | 60 | 70 | 75 | 70 | 90 | 105 |
| Factor for pry-out failure | k_8 | [-] | 1,0 | | | | | | 2,0 | | |
| Installation factor | γ_{inst} | [-] | 1,0 | | | | | | | | |
| Concrete edge failure | | | | | | | | | | | |
| Effective length in concrete | $l_f = h_{ef}$ | [mm] | 31 | 44 | 35 | 43 | 52 | 43 | 60 | 68 | |
| Nominal outer diameter of screw | d_{nom} | [mm] | 6 | | | 8 | | | 10 | | |
| TURBO SMART concrete screw | | | | | | | | | | Annex C1 | |
| Performances Characteristic values for static and quasi-static loading, sizes 6,8,10 | | | | | | | | | | | |

Table C2: Characteristic values for static and quasi-static loading, sizes 12 and 14

| TURBO SMART concrete screw size | | 12 | | | 14 | | |
|---------------------------------|-----------|------------|------------|------------|------------|------------|------------|
| Nominal embedment depth | h_{nom} | h_{nom1} | h_{nom2} | h_{nom3} | h_{nom1} | h_{nom2} | h_{nom3} |
| | [mm] | 65 | 85 | 100 | 75 | 100 | 115 |

| Steel failure for tension and shear loading | | | | | | | |
|---|-----------------|------|-------|------|------|-------|--|
| Characteristic tension load | $N_{RK,s}$ | [kN] | 67,0 | | | 94,0 | |
| Partial factor tension load | $\gamma_{Ms,N}$ | [-] | 1,5 | | | | |
| Characteristic shear load | $V_{RK,s}$ | [kN] | 33,5 | 42,0 | 56,0 | | |
| Partial factor shear load | $\gamma_{Ms,V}$ | [-] | 1,25 | | | | |
| Ductility factor | k_7 | [-] | 0,8 | | | | |
| Characteristic bending load | $M^0_{RK,s}$ | [Nm] | 113,0 | | | 185,0 | |

| Pull-out failure | | | | | | | |
|------------------------------------|-----------|------------|------|------|-------------------|--|--|
| Characteristic tension load C20/25 | cracked | $N_{RK,p}$ | [kN] | 12,0 | $\geq N^0_{RK,c}$ | | |
| | uncracked | $N_{RK,p}$ | [kN] | 16,0 | | | |
| Increasing factor for $N_{RK,p}$ | C20/25 | ψ_c | [-] | 1,12 | | | |
| | C30/37 | | | 1,22 | | | |
| | C40/50 | | | 1,41 | | | |
| | C50/60 | | | 1,58 | | | |

| Concrete failure: Splitting failure, concrete cone failure and pry-out failure | | | | | | | | | |
|--|-----------------|-----------------|------|---------------------|-----|-----|-----|-----|-----|
| Effective embedment depth | h_{ef} | [mm] | 50 | 67 | 80 | 58 | 79 | 92 | |
| k-factor | cracked | $k_1 = k_{cr}$ | [-] | 7,7 | | | | | |
| | uncracked | $k_1 = k_{ucr}$ | [-] | 11,0 | | | | | |
| Concrete cone failure | spacing | $s_{cr,N}$ | [mm] | $3 \times h_{ef}$ | | | | | |
| | edge distance | $c_{cr,N}$ | [mm] | $1,5 \times h_{ef}$ | | | | | |
| Splitting failure | spacing | $s_{cr,Sp}$ | [mm] | 150 | 210 | 240 | 180 | 240 | 280 |
| | edge distance | $c_{cr,Sp}$ | [mm] | 75 | 105 | 120 | 90 | 120 | 140 |
| Factor for pry-out failure | k_8 | [-] | 1,0 | 2,0 | | 1,0 | 2,0 | | |
| Installation factor | γ_{inst} | [-] | 1,0 | | | | | | |

| Concrete edge failure | | | | | | | | |
|---------------------------------|----------------|------|----|----|----|----|----|----|
| Effective length in concrete | $l_f = h_{ef}$ | [mm] | 50 | 67 | 80 | 58 | 79 | 92 |
| Nominal outer diameter of screw | d_{nom} | [mm] | 12 | | | 14 | | |

TURBO SMART concrete screw

Performances

Characteristic values for static and quasi-static loading, sizes 12 and 14

Annex C2

Table C3: Seismic category C1 – Characteristic load values

| TURBO SMART concrete screw size | | | 8 | 10 | 12 | 14 |
|--|-----------------|------|---------------------|-------------------|------|------|
| Nominal embedment depth | h_{nom} | | h_{nom3} | | | |
| | [mm] | | 65 | 85 | 100 | 115 |
| Steel failure for tension and shear load | | | | | | |
| Characteristic load | $N_{Rk,s,eq}$ | [kN] | 27,0 | 45,0 | 67,0 | 94,0 |
| Partial factor tension load | γ_{Ms} | [-] | 1,5 | | | |
| Characteristic load | $V_{Rk,s,eq}$ | [kN] | 8,5 | 15,3 | 21,0 | 22,4 |
| Partial factor shear load | γ_{Ms} | [-] | 1,25 | | | |
| With filling of the annular gap ¹⁾ | α_{gap} | [-] | 1,0 | | | |
| Without filling of the annular gap | α_{gap} | [-] | 0,5 | | | |
| Pull-out failure | | | | | | |
| Characteristic tension load in cracked concrete C20/25 | $N_{Rk,p,eq}$ | [kN] | 12,0 | $\geq N_{Rk,c}^0$ | | |
| Concrete cone failure | | | | | | |
| Effective embedment depth | h_{ef} | [mm] | 52 | 68 | 80 | 92 |
| Edge distance | $c_{cr,N}$ | [mm] | $1,5 \times h_{ef}$ | | | |
| Spacing | $s_{cr,N}$ | [mm] | $3 \times h_{ef}$ | | | |
| Installation safety factor | γ_{inst} | [-] | 1,0 | | | |
| Concrete pry-out failure | | | | | | |
| Factor for pry-out failure | k_8 | [-] | 1,0 | 2,0 | | |
| Concrete edge failure | | | | | | |
| Effective length in concrete | $l_f = h_{ef}$ | [mm] | 52 | 68 | 80 | 92 |
| Nominal outer diameter of screw | d_{nom} | [mm] | 8 | 10 | 12 | 14 |

1) Filling of the annular gap according to annex B7, figure 7

TURBO SMART concrete screw

Performances

Seismic category C1 – Characteristic load values

Annex C3

Table C4: Seismic category C2 ¹⁾ – Characteristic load values with filled annular gap according to annex B7, figure 7

| TURBO SMART concrete screw size | | | 8 | 10 | 12 | 14 |
|---|-----------------|------------|----------------|------|------|------|
| Nominal embedment depth | h_{nom} | h_{nom3} | | | | |
| | [mm] | 65 | 85 | 100 | 115 | |
| Steel failure for tension | | | | | | |
| Characteristic load | $N_{Rk,s,eq}$ | [kN] | 27,0 | 45,0 | 67,0 | 94,0 |
| Partial factor tension load | γ_{Ms} | [-] | 1,5 | | | |
| With filling of the annular gap | α_{gap} | [-] | 1,0 | | | |
| Pull-out failure | | | | | | |
| Characteristic load in cracked concrete | $N_{Rk,p,eq}$ | [kN] | 2,4 | 5,4 | 7,1 | 10,5 |
| Steel failure for shear load | | | | | | |
| Characteristic load | $V_{Rk,s,eq}$ | [kN] | 9,9 | 18,5 | 31,6 | 40,7 |
| Partial factor shear load | γ_{Ms} | [-] | 1,25 | | | |
| With filling of the annular gap | α_{gap} | [-] | 1,0 | | | |
| Concrete cone failure | | | | | | |
| Effective embedment depth | h_{ef} | [mm] | 52 | 68 | 80 | 92 |
| Edge distance | $c_{cr,N}$ | [mm] | 1,5 x h_{ef} | | | |
| Spacing | $s_{cr,N}$ | [mm] | 3 x h_{ef} | | | |
| Installation safety factor | γ_{inst} | [-] | 1,0 | | | |
| Concrete pry-out failure | | | | | | |
| Factor for pry-out failure | k_8 | [-] | 2,0 | | | |
| Concrete edge failure | | | | | | |
| Effective length in concrete | $l_f = h_{ef}$ | [mm] | 52 | 68 | 80 | 92 |
| Nominal outer diameter of screw | d_{nom} | [mm] | 8 | 10 | 12 | 14 |

1) A4 and HCR not suitable

TURBO SMART concrete screw

Performances

Seismic category C2 – Characteristic load values with filled annular gap

Annex C4

Table C5: Seismic category C2 ¹⁾ – Characteristic load values without filled annular gap according to annex B7, figure 5

| TURBO SMART concrete screw size | | | 8 | 10 | 12 | 14 |
|---|-----------------|------|----------------|------|------|------|
| Nominal embedment depth | h_{nom} | | h_{nom3} | | | |
| | [mm] | | 65 | 85 | 100 | 115 |
| Steel failure for tension (hexagon head type) | | | | | | |
| Characteristic load | $N_{RK,s,eq}$ | [kN] | 27,0 | 45,0 | 67,0 | 94,0 |
| Partial factor tension load | γ_{Ms} | [-] | 1,5 | | | |
| Pull-out failure (hexagon head type) | | | | | | |
| Characteristic load in cracked concrete | $N_{RK,p,eq}$ | [kN] | 2,4 | 5,4 | 7,1 | 10,5 |
| Steel failure for shear load (hexagon head type) | | | | | | |
| Characteristic load | $V_{RK,s,eq}$ | [kN] | 10,3 | 21,9 | 24,4 | 23,3 |
| Partial factor shear load | γ_{Ms} | [-] | 1,25 | | | |
| Without filling of the annular gap | α_{gap} | [-] | 0,5 | | | |
| Steel failure for tension (countersunk head type) | | | | | | |
| Characteristic load | $N_{RK,s,eq}$ | [kN] | 27,0 | 45,0 | - | |
| Partial factor tension load | γ_{Ms} | [-] | 1,5 | | | |
| Pull-out failure (countersunk head type) | | | | | | |
| Characteristic load in cracked concrete | $N_{RK,p,eq}$ | [kN] | 2,4 | 5,4 | - | |
| Steel failure for shear load (countersunk head type) | | | | | | |
| Characteristic load | $V_{RK,s,eq}$ | [kN] | 3,6 | 13,7 | - | |
| Partial factor shear load | γ_{Ms} | [-] | 1,25 | | | |
| Without filling of the annular gap | α_{gap} | [-] | 0,5 | | | |
| Concrete cone failure | | | | | | |
| Effective embedment depth | h_{ef} | [mm] | 52 | 68 | 80 | 92 |
| Edge distance | $c_{cr,N}$ | [mm] | 1,5 x h_{ef} | | | |
| Spacing | $s_{cr,N}$ | [mm] | 3 x h_{ef} | | | |
| Installation safety factor | γ_{inst} | [-] | 1,0 | | | |
| Concrete pry-out failure | | | | | | |
| Factor for pry-out failure | k_s | [-] | 2,0 | | | |
| Concrete edge failure | | | | | | |
| Effective length in concrete | $l_f = h_{ef}$ | [mm] | 52 | 68 | 80 | 92 |
| Nominal outer diameter of screw | d_{nom} | [mm] | 8 | 10 | 12 | 14 |

1) A4 and HCR not suitable

TURBO SMART concrete screw

Performances

Seismic category C2 – Characteristic load values without filled annular gap

Annex C5

Table C7: Displacements under static and quasi-static tension load

| TURBO SMART concrete screw size | | | | 6 | | | 8 | | | 10 | | |
|---------------------------------|--------------|--------------------|------|-----------|------------|------------|------------|------------|------------|------------|------------|------------|
| Nominal embedment depth | | | | h_{nom} | h_{nom1} | h_{nom2} | h_{nom1} | h_{nom2} | h_{nom3} | h_{nom1} | h_{nom2} | h_{nom3} |
| | | | | [mm] | 40 | 55 | 45 | 55 | 65 | 55 | 75 | 85 |
| Cracked concrete | tension load | N | [kN] | 0,95 | 1,9 | 2,4 | 4,3 | 5,7 | 4,3 | 7,9 | 9,6 | |
| | displacement | δ_{N0} | [mm] | 0,3 | 0,6 | 0,6 | 0,7 | 0,8 | 0,6 | 0,5 | 0,9 | |
| | | $\delta_{N\infty}$ | [mm] | 0,4 | 0,4 | 0,6 | 1,0 | 0,9 | 0,4 | 1,2 | 1,2 | |
| Uncracked concrete | tension load | N | [kN] | 1,9 | 4,3 | 3,6 | 5,7 | 7,6 | 5,7 | 9,5 | 11,9 | |
| | displacement | δ_{N0} | [mm] | 0,4 | 0,6 | 0,7 | 0,9 | 0,5 | 0,7 | 1,1 | 1,0 | |
| | | $\delta_{N\infty}$ | [mm] | 0,4 | 0,4 | 0,6 | 1,0 | 0,9 | 0,4 | 1,2 | 1,2 | |

| TURBO SMART concrete screw size | | | | 12 | | | 14 | | | |
|---------------------------------|--------------|--------------------|------|-----------|------------|------------|------------|------------|------------|------------|
| Nominal embedment depth | | | | h_{nom} | h_{nom1} | h_{nom2} | h_{nom3} | h_{nom1} | h_{nom2} | h_{nom3} |
| | | | | [mm] | 65 | 85 | 100 | 75 | 100 | 115 |
| Cracked concrete | tension load | N | [kN] | 5,7 | 9,4 | 12,3 | 7,6 | 12,0 | 15,1 | |
| | displacement | δ_{N0} | [mm] | 0,9 | 0,5 | 1,0 | 0,5 | 0,8 | 0,7 | |
| | | $\delta_{N\infty}$ | [mm] | 1,0 | 1,2 | 1,2 | 0,9 | 1,2 | 1,0 | |
| Uncracked concrete | tension load | N | [kN] | 7,6 | 13,2 | 17,2 | 10,6 | 16,9 | 21,2 | |
| | displacement | δ_{N0} | [mm] | 1,0 | 1,1 | 1,2 | 0,9 | 1,2 | 0,8 | |
| | | $\delta_{N\infty}$ | [mm] | 1,0 | 1,2 | 1,2 | 0,9 | 1,2 | 1,0 | |

Table C8: Displacements under static and quasi-static shear load

| TURBO SMART concrete screw size | | | | 6 | | | 8 | | | 10 | | |
|---------------------------------|--------------|--------------------|------|-----------|------------|------------|------------|------------|------------|------------|------------|------------|
| Nominal embedment depth | | | | h_{nom} | h_{nom1} | h_{nom2} | h_{nom1} | h_{nom2} | h_{nom3} | h_{nom1} | h_{nom2} | h_{nom3} |
| | | | | [mm] | 40 | 55 | 45 | 55 | 65 | 55 | 75 | 85 |
| Cracked and uncracked concrete | shear load | V | [kN] | 3,3 | | | 8,6 | | | 16,2 | | |
| | displacement | δ_{V0} | [mm] | 1,55 | | | 2,7 | | | 2,7 | | |
| | | $\delta_{V\infty}$ | [mm] | 3,1 | | | 4,1 | | | 4,3 | | |

| TURBO SMART concrete screw size | | | | 12 | | | 14 | | | |
|---------------------------------|--------------|--------------------|------|-----------|------------|------------|------------|------------|------------|------------|
| Nominal embedment depth | | | | h_{nom} | h_{nom1} | h_{nom2} | h_{nom3} | h_{nom1} | h_{nom2} | h_{nom3} |
| | | | | [mm] | 65 | 85 | 100 | 75 | 100 | 115 |
| Cracked and uncracked concrete | shear load | V | [kN] | 20,0 | | | 30,5 | | | |
| | displacement | δ_{V0} | [mm] | 4,0 | | | 3,1 | | | |
| | | $\delta_{V\infty}$ | [mm] | 6,0 | | | 4,7 | | | |

TURBO SMART concrete screw

Performances
Displacements under static and quasi-static loads

Annex C7

Table C9: Seismic category C2 ¹⁾ – Displacements with filled annular gap according to annex B7, figure 7

| TURBO SMART concrete screw size | | | 8 | 10 | 12 | 14 |
|--|----------------------------|------------|------|------|------|------|
| Nominal embedment depth | h_{nom} | h_{nom3} | | | | |
| | [mm] | 65 | 85 | 100 | 115 | |
| Displacements under tension loads (hexagon head type) | | | | | | |
| Displacement DLS | $\bar{\delta}_{N,eq(DLS)}$ | [mm] | 0,66 | 0,32 | 0,57 | 1,16 |
| Displacement ULS | $\bar{\delta}_{N,eq(ULS)}$ | [mm] | 1,74 | 1,36 | 2,36 | 4,39 |
| Displacements under shear loads (hexagon head type with hole clearance) | | | | | | |
| Displacement DLS | $\bar{\delta}_{V,eq(DLS)}$ | [mm] | 1,68 | 2,91 | 1,88 | 2,42 |
| Displacement ULS | $\bar{\delta}_{V,eq(ULS)}$ | [mm] | 5,19 | 6,72 | 5,37 | 9,27 |

Table C10: Seismic category C2 ¹⁾ – Displacements without filled annular gap according to annex B7, figure 5

| TURBO SMART concrete screw size | | | 8 | 10 | 12 | 14 |
|--|----------------------------|------------|------|------|------|-------|
| Nominal embedment depth | h_{nom} | h_{nom3} | | | | |
| | [mm] | 65 | 85 | 100 | 115 | |
| Displacements under tension loads (hexagon head type) | | | | | | |
| Displacement DLS | $\bar{\delta}_{N,eq(DLS)}$ | [mm] | 0,66 | 0,32 | 0,57 | 1,16 |
| Displacement ULS | $\bar{\delta}_{N,eq(ULS)}$ | [mm] | 1,74 | 1,36 | 2,36 | 4,39 |
| Displacements under tension loads (countersunk head type) | | | | | | |
| Displacement DLS | $\bar{\delta}_{N,eq(DLS)}$ | [mm] | 0,66 | 0,32 | - | |
| Displacement ULS | $\bar{\delta}_{N,eq(ULS)}$ | [mm] | 1,74 | 1,36 | | |
| Displacements under shear loads (hexagon head type with hole clearance) | | | | | | |
| Displacement DLS | $\bar{\delta}_{V,eq(DLS)}$ | [mm] | 4,21 | 4,71 | 4,42 | 5,60 |
| Displacement ULS | $\bar{\delta}_{V,eq(ULS)}$ | [mm] | 7,13 | 8,83 | 6,95 | 12,63 |
| Displacements under shear loads (countersunk head type with hole clearance) | | | | | | |
| Displacement DLS | $\bar{\delta}_{V,eq(DLS)}$ | [mm] | 2,51 | 2,98 | - | |
| Displacement ULS | $\bar{\delta}_{V,eq(ULS)}$ | [mm] | 7,76 | 6,25 | | |

1) A4 and HCR not suitable

TURBO SMART concrete screw

Performances

Displacements under seismic loads

Annex C8